



## Why on earth does my bonding need checking?

Have you decided to have additional electrical socket outlets, new lighting points, a new circuit installed (such as an electric shower) or any alterations to electrical circuits in your home? If so a NAPIT registered electrician is required, prior to starting work, to verify the earthing and protective bonding arrangements are adequate.

After completion of the electrical installation work no matter how small the job, the work shall be inspected and tested and a certificate issued. Part of this process is to verify that the earthing and bonding conductors are correctly sized, installed and terminated correctly.

# Earthing and bonding explained

Earthing is used to protect people from the risk of electric shock. If the earthing arrangements within your electrical installation were defective or inadequate, you could receive an electric shock from the equipment or appliance metal casing.

The purpose of earthing is to provide a path for electric fault current to flow safely to earth to enable the circuit breaker or fuse to operate.

Bonding is the connection of the incoming metal gas and water pipes to the main installation earthing terminal and is vital for your protection from electric shock.

In a correctly earthed installation, any appliance or equipment developing a fault to the metal casing, will be quickly disconnected by the operation of the circuit fuse or circuit breaker.

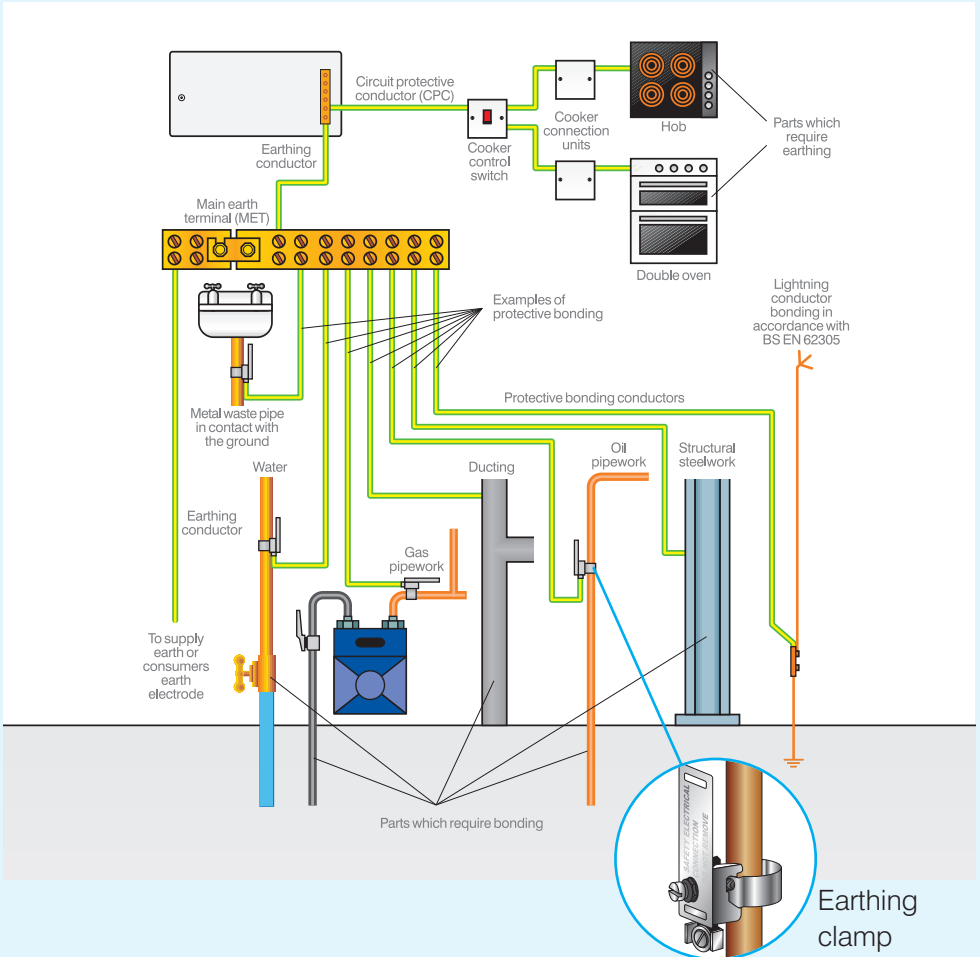

# Supplementary bonding explained

Supplementary bonding is often found in bathrooms or any other room containing a bath or shower. This is to reduce the risk of electric shock where people may touch two separate metal parts, such as radiators and water pipes, when a electrical fault occurs in the electrical installation.

In these locations supplementary protective bonding conductors connect together the circuit protective conductors of electrical equipment e.g. electric shower to hot and cold metal

water pipes and any metal radiators or towel rails.

As illustrated this arrangement was common on installations up to June 30th 2008. With the introduction of new IEE Wiring Regulations BS7671 (2008), after this date the need for supplementary bonding has been reduced, as all electrical installations in rooms containing a new bath or shower need to have their circuits additionally protected by a Residual Current Device (RCD).

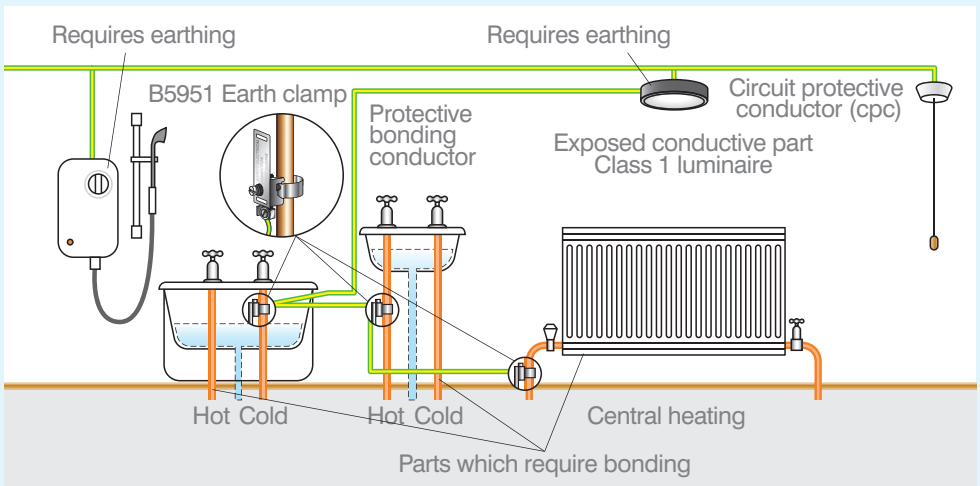

**Earthing Conductor** A protective conductor connecting the main earthing terminal of an installation to an earth electrode or other means of earthing.

**Circuit Protective Conductor (CPC)**  
A protective conductor connecting exposed conducting parts of equipment to the main earthing terminal.

**Protective Bonding Conductor**  
Protective conductor provided for protective equipotential bonding.

**Residual Current Device** a protective device which operates when an earth fault is detected.

**Earth** The conductive mass of the earth, whose electric potential at any point is conventionally taken as zero.

## What do I need to do?

Correctly installed earthing and bonding can protect you from the risk of electrocution and fire caused by faulty equipment or appliances.

A NAPIT registered electrician can advise you on whether your earthing and bonding installation requires improvements to maintain your safety in the event of an electrical fault occurring.

YOUR NAPIT MEMBER IS



08451 303 319



NAPIT can recommend a qualified electrician near you. Just call NAPIT on 0845 543 0330  
[info@napit.org.uk](mailto:info@napit.org.uk) [www.napit.org.uk](http://www.napit.org.uk)